

Accuphase

BALANCED STEREO POWER AMPLIFIER

P-800

- Completely balanced, powerful output stage consisting of two sets of 7 parallel push-pull transistor pairs
- Outstanding low-impedance drive capability
- Separate power supplies for left and right channels
- Balanced input



Balanced Amplifiers

Two power units, each containing 7 parallel push-pull transistor pairs are connected

When switched to low-impedance drive, guaranteed output power is an amazing

Ever since the advent of pulse coding method to record electric signals, the world of reproduced music is about to undergo significant changes, because the digital recording technology has brought about substantial improvement in the reality of the reproduced music. Moreover, minute and subtle reverberation components, which are essential to reproduce the atmosphere of the original sounds, can now be recorded with utmost accuracy.

Needless to say, accurate transmission of signals is indispensable in the reproduced sound fields; otherwise, we cannot even appreciate the reproduced music and, in the worst case, we may not be able to perceive what we listen to as music but nothing more than collection of noises. Equally important for reproducing music, however, is an amplifier that can correctly amplify even reverberation components to the extent that you feel, when you listen to reproduced music, as if the music were being played by an orchestra right in front of you. Without such an amplifier, the atmosphere of beautiful and elegant music cannot be reproduced. It is therefore vital for a power amplifier to be able to yield power of high amplitude and, at the same time, to amplify minute signals superimposed on the electric signals it amplifies, with high fidelity. However, the power an amplifier can produce and its fidelity are, in many cases, in a mutual contradictory relation, and the higher power an amplifier can produce, the lower its fidelity in reproducing minute signals and reverberation components. The P-800, which was developed with Accuphase's technology that has already produced a superb monophonic amplifier, M-1000, is an exceptional power amplifier in this respect as it can yield a power of as high as 600 watts (into 4-ohm loads), but reproduce even reverberation components with high fidelity, which is not possible with most of the amplifiers on the market today. It uses two power units in bridged configuration, forming a totally balanced amplifier. Meticulous attention has been paid to every detail, and original Accuphase technology is used throughout, with the aim to improve quality especially at low signal levels. The impedance of loudspeakers on the market varies considerably, ranging from about 2 ohms to 16 ohms. With a direct-coupled amplifier,

driving such a wide impedance range with equal aplomb is almost impossible. An output stage designed for optimum performance at 2 ohms will deliver less power into 8 to 16 ohms. Conversely, the performance of an amplifier optimized for about 4 to 8 ohms suffers at 2 ohms and it will not be capable of driving 1-ohm loads. The P-800 incorporates a special design to deal with a wide range of load impedances. The applied voltage of its output devices can be switched to a lower value, to provide the high current capability required by low-impedance loads. This results in a truly amazing guaranteed rating of 600 watts into 1 ohm and 400 watts into 2 ohms, with undiminished sound quality. To achieve such stunning performance, the output stage of each power unit employs two sets of seven parallel push-pull pairs of wide-band transistors with a maximum power dissipation (P_C) of 130 watts each. This amounts to 14 pairs or 28 transistors per unit, totaling a maximum power dissipation of 3.6 kilowatts. These truly astounding figures testify to the no-holds-barred design approach of the P-800.

To let you monitor its performance, the P-800 incorporates two symmetrically arranged analog level meters.

The beautiful and simple elegance of this amplifier's external appearance belies its awesome performance. But when turned on, it speaks unmistakably through music.

of noise induced during the transmission process but even of distortion components arising within the amplifier. This cancellation takes place in the output circuits, and the overall effect is a signal of pure and undiluted quality. The Accuphase P-800 uses two separate power amplifier units with push-pull drive in bridged connection, for the ultimate in performance and sound quality.

2 Accurate reproduction of sound field with two independent power supplies

In the P-800, two power supply units with separate transformers for both the left and the right channels are provided with each transformer yielding a capacity of 1.5 kVA. This design cuts the power supply impedance as seen by the amplifier in half. Moreover, four 82,000- μ F filter capacitors that determine the sound quality in a low frequency region are employed, totaling a capacitance of 328,000 μ F, so that stable low-frequency sounds can be reproduced.

3 Ultra-powerful output stages consisting of two sets of seven parallel push-pull transistor pairs each

Fig. 2 shows the output stage of the P-800. Two exactly identical amplifier units are used in bridged configuration. The input signal is connected to these units with inverted phase, resulting in a combined output power rating of 600 W into 4 ohms and 400 W into 8 ohms. This impressive power is achieved by an extravagant design involving two sets of seven parallel push-pull transistor pairs in each amplifier unit. Each transistor has a maximum power dissipation (P_C) of 130 watts. As there are a total of 28 transistors, the combined maximum power dissipation amounts to an astounding 3.6 kilowatts. Accuphase never sacrifices quality for quantity. Topnotch design and construction throughout ensure that this awe-inspiring power is delivered with impeccable fidelity. Large heat sinks made of solid aluminum permit operation under normal conditions without cooling fans.

1 Totally balanced construction with two separate power units for ultimate sound quality

The two basic principles shown in Fig. 1 are available to transmit signals in an audio system: (a) unbalanced, and (b) balanced lines. The widely used unbalanced principle permits simpler circuit design, as can be seen from the chart, but this approach involves the possibility of sound quality degradation, because the ground line carries the signal current, DC components to drive the amplifier, and often induced noise from external interference sources. The more elaborate balanced approach requires two separate lines which carry the non-inverted signal and inverted signal. An inherent advantage of this principle is the cancellation not only

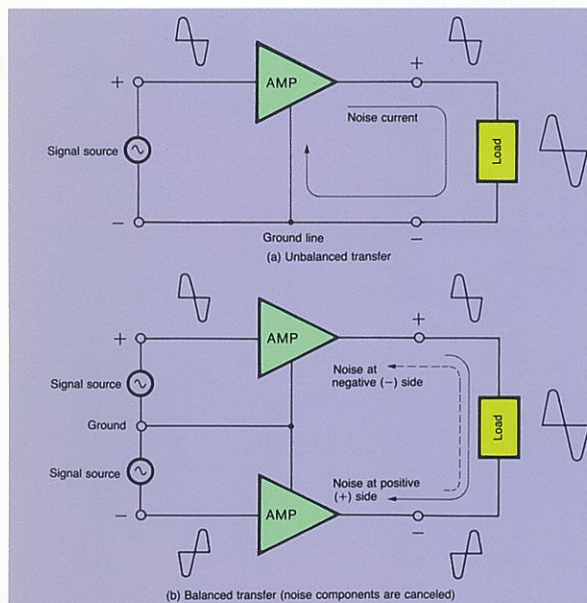

Fig. 1 Two Signal Transfer Methods

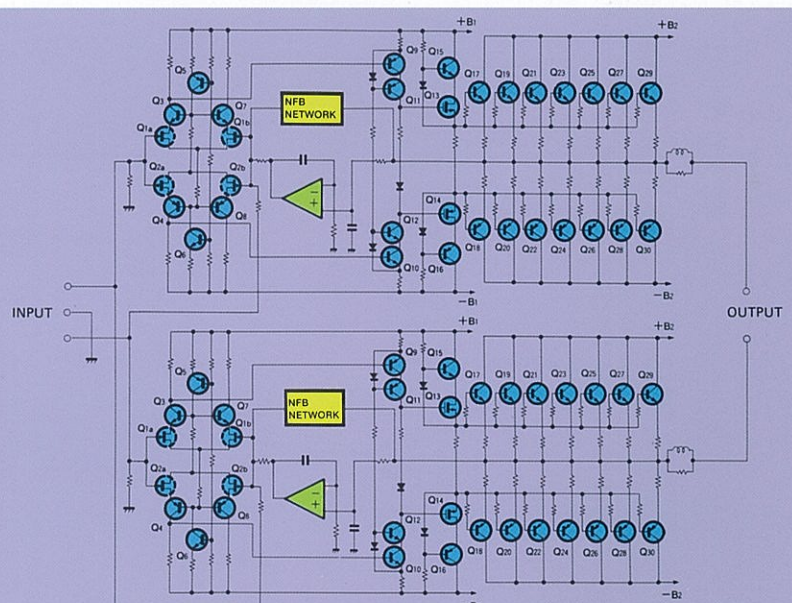
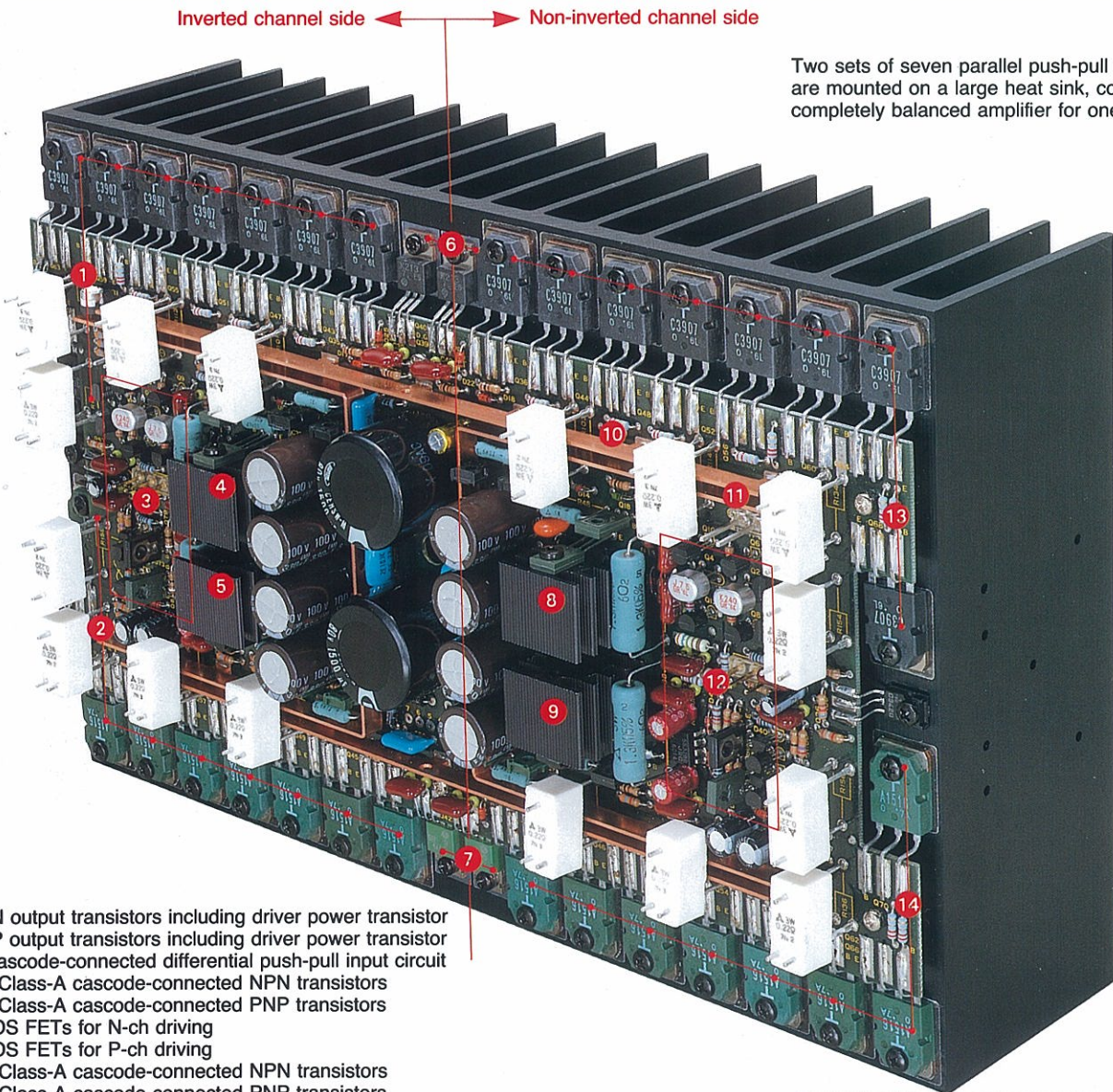

Fig. 2 Block Diagram of P-800 (One-Channel)

1 in balanced configuration to produce 400 watts into 8 ohms, and 600 watts into 4 ohms, and 600 watts into 2 ohms and 600 watts into 1 ohms.



Two sets of seven parallel push-pull transistor pairs are mounted on a large heat sink, configuring a completely balanced amplifier for one channel.

- 1 Eight NPN output transistors including driver power transistor
- 2 Eight PNP output transistors including driver power transistor
- 3 Class-A cascode-connected differential push-pull input circuit
- 4 Predriver Class-A cascode-connected NPN transistors
- 5 Predriver Class-A cascode-connected PNP transistors
- 6 Power MOS FETs for N-ch driving
- 7 Power MOS FETs for P-ch driving
- 8 Predriver Class-A cascode-connected NPN transistors
- 9 Predriver Class-A cascode-connected PNP transistors
- 10 +B power bus bar
- 11 NON-INVERTED channel output bus bar
- 12 Class-A cascode-connected differential push-pull input circuit
- 13 Eight NPN transistors including driver power transistor
- 14 Eight PNP transistors including driver power transistor

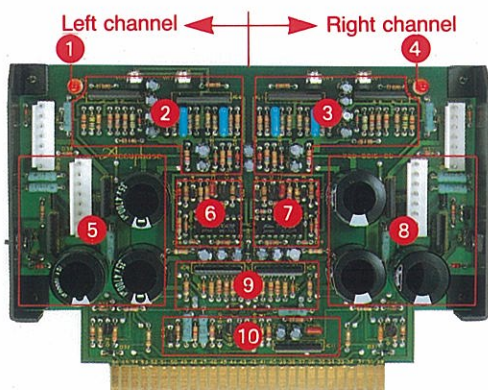

- 1 Overheat indicator (LED)
- 2 Left channel power meter driver
- 3 Right channel power meter driver
- 4 Overheat indicator (LED)
- 5 Power supply circuit for other than signal path
- 6 Frequency counter for left channel muting
- 7 Frequency counter for right channel muting
- 8 Power supply circuit for other than signal path
- 9 Protection circuit
- 10 Low-load impedance drive selector circuit

PC board with meter driver circuits, protection circuit, impedance selector circuit, etc.

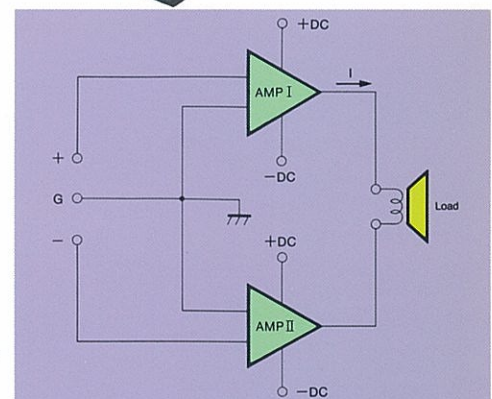

Item	NORMAL	LOW
Applied DC voltage	±53 V	±33 V
Max. current	1 kHz, 1 wave	175 A
	100 Hz, 1 wave	110 A
	10 Hz, 1 wave	35 A
	DC	18 A

The output current values calculated from the area of safety operation of the transistors

Fig. 3 Voltage Applied to Output Stage vs. Maximum Current

Accuphase P-800

STEREO POWER AMPLIFIER

4 Excellent low-impedance drive capability — 600 watts into 1 ohm, 400 watts into 2 ohms

As the operating conditions of an amplifier vary considerably depending on low impedance, it is not possible to achieve high current capability for speaker loads ranging from 1 to 16 ohms with exactly the same amplifier configuration. To effectively supply power to speakers with an impedance of 4 ohms and above, the drive voltage of the output stage must be high. However, if the output elements are driven at a high voltage in order to supply a high drive voltage to the loads, the maximum supply current decreases, making it impossible to supply a high output power to loads with a low impedance. It is therefore necessary to lower the voltage applied to the output elements and thereby to increase the current supply capability of the amplifier.

Fig. 3 shows the maximum current the P-800 can supply to the loads when a given voltage is applied to its output elements. These characteristics were calculated based on the stable operation region of the transistors. As can be seen from this figure and table, the maximum current decreases as the frequency lowers. If the input signal exceeds the maximum output current, or if the load impedance falls below the permissible value, the output transistors break down. If the applied voltage is lowered, however, a high current can be output, as indicated by value [LOW], at a frequency lower than [NORMAL].

Making the use of these basic operating principles of transistors, the P-800 is designed so that a high power can be supplied to even low-impedance loads. The "LOW LOAD IMPEDANCE" switch makes it possible to supply a full 600 watts into 1 ohm and 400 watts into 2 ohms. Thanks to this design, the P-800 is fully capable of driving "difficult" flat diaphragm speakers or electrostatic speakers with low efficiency and low impedance ratings.

5 Cascode differential push-pull input stage tuned for perfection

To make full use of the performance capabilities of the balanced output stages, the amplifier's input stage must also conform to highest quality standards. To achieve this aim, all Accuphase power amplifiers use a class A cascode differential push-pull circuit configuration in the input stage. As can be seen from Fig. 2, the transistors Q_{1a} and Q_3 , Q_{2a} and Q_4 , Q_{1b} and Q_7 , as well as Q_{2b} and Q_8 are cascode connected in both amplifiers. The cascode-connection principle was developed for radio frequency amplification. It guarantees stable operation over a wide range, resulting in outstanding input linearity and wide dynamic range.

6 "Cascode push-pull + MOS FET cascode push-pull" drive stage for minimum distortion at low levels and superior high-range stability

The dynamic impact of an orchestra playing at resounding levels and the minute detail of a delicate pianissimo passage — both of these aspects are essential for true music reproduction. With conventional high-power amplifiers, performance at low levels is often found wanting. Not so in the case of Accuphase components, which are built to deliver utterly convinc-

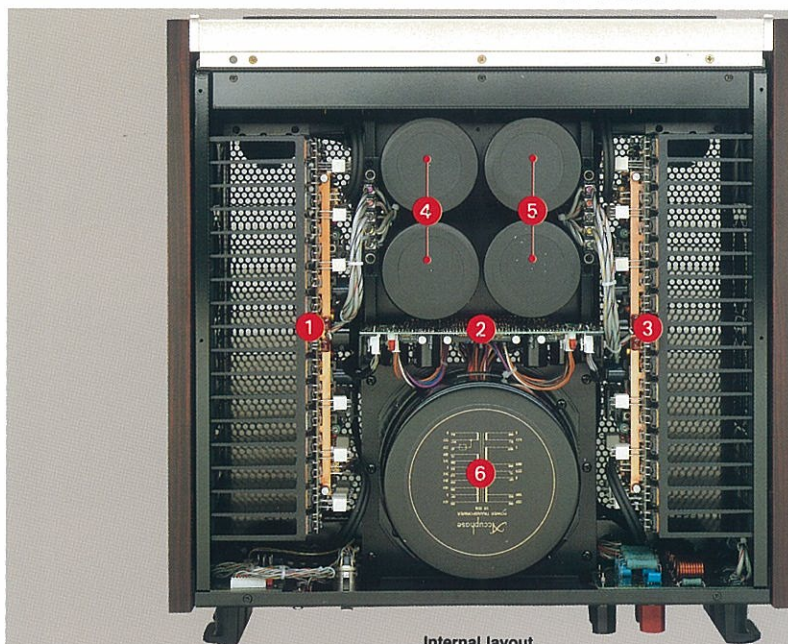

Internal layout

- 1 Right channel power amplifier unit
- 2 PC board with meter driver circuits, protection circuit, impedance selector circuit, etc.
- 3 Left channel power amplifier unit
- 4 Right channel filter capacitors
- 5 Left channel filter capacitors
- 6 This power transformer is for the left channel. Underneath of this transformer is the one for the right channel.

ing performance at both ends of the loudness spectrum.

In the output stage, the operating points of the PNP and NPN transistors are carefully adjusted so as to avoid cutoff (current flow interruption), thereby eliminating switching distortion at low signal levels. The final predriver stage employs MOS FET devices, which is equivalent to non-switching class A drive. Cascode push-pull topology further improves performance. The drive current for this stage is supplied by another class A cascode push-pull arrangement. The overall result of this approach is absolutely negligible distortion and totally stable operation from the noise threshold up to full rated power, under any load condition.

7 Large analog power meters reading -60 to +3 dB

The output meters are large analog meters symmetrically arranged. They can directly read the output power in decibel units over a range as wide as from -60 (0.0004 watts/8 ohms) to +3 (800 watts/8 ohms) dB. The meters can be activated and deactivated or the illumination of the meters can be turned on or off by a switch.

8 40-kilohm balanced input and 20-kilohm unbalanced photo jack

Although using a preamplifier with balanced output is preferable for optimum performance, the P-800 will deliver superior quality also with an unbalanced connection using regular RCA-type photo connectors. A switch located on the subpanel on the front side of the amplifier gives a choice of input configurations.

9 Mounting provisions for cooling fans

In normal operation, the P-800 does not require any forced cooling. Only if used in a location where proper ventilation may be obstructed or in professional applications where very high power levels are drawn for long periods, installation of optional cooling fans which can be mounted on the inside of the side panels is recommended. For this purpose, the fan kit O-83 is available from your Accuphase dealer.

10 Natural persimmon-wood side panels

Except for the power switch, all controls are located behind a hinged subpanel door in the lower section of the front panel. The panel is finished in brushed gold aluminum, giving the P-800 an appearance of simple elegance. The visual appeal of the amplifier is further enhanced by the side panels made of exquisite persimmon-wood.



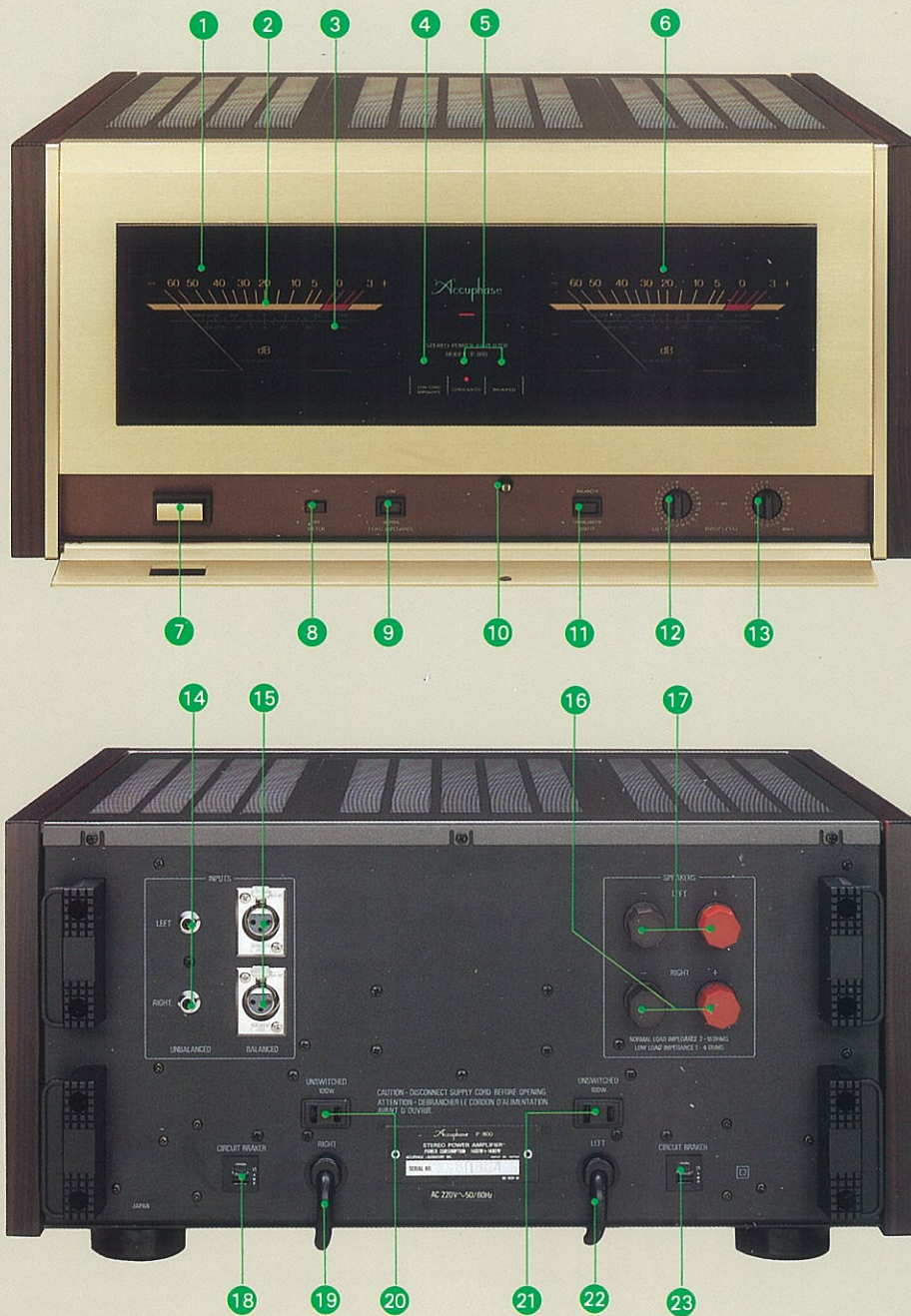

- 1 Left channel output meter
- 2 dB SCALE of output meter
- 3 Output meter wattage scale
- 4 Low-impedance drive indicator LED
- 5 Input indicator LEDs (UNBALANCED/BALANCED)
- 6 Right channel output meter
- 7 Power switch
- 8 Meter operation/illumination switch
- 9 Load impedance selector switch (NORMAL/LOW)
- 10 Subpanel magnet lock
- 11 Input selector switch (UNBALANCED/BALANCED)
- 12 Left channel input level controller (up to -20 dB, adjustable in units of 1 dB)
- 13 Right channel input level controller (up to -20 dB, adjustable in units of 1 dB)

- 14 Unbalanced input jack (input impedance: $20\text{ k}\Omega$)
- 15 Balanced input connector (input impedance: $40\text{ k}\Omega$) XLR-3-31 type connector [(1): GND, (2): INVERTED, (3): NON-INVERTED], suitable for XLR-3-12C type plug
- 16 Right channel speaker output terminal
- 17 Left channel speaker output terminal
- 18 Right channel circuit breaker
- 19 Right channel AC power cord
- 20 AC outlet (unswitched)
- 21 AC outlet (unswitched)
- 22 Left channel AC power cord
- 23 Left channel circuit breaker

Accuphase P-800

STEREO POWER AMPLIFIER

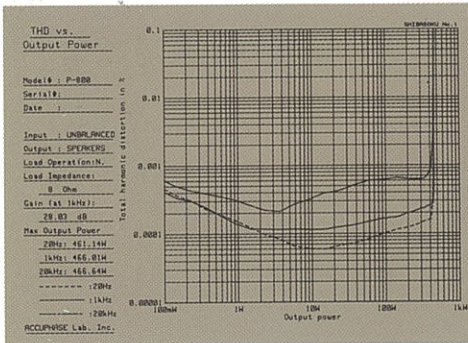

● OUTPUT POWER vs. TOTAL HARMONIC DISTORTION (at 8 ohms, NORMAL IMP mode)

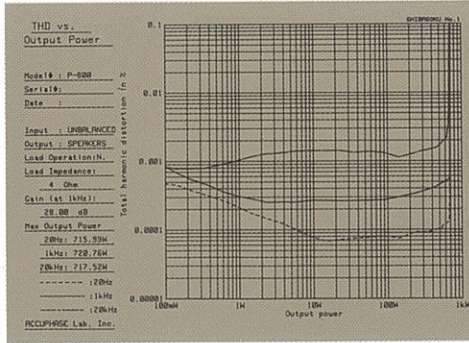

● OUTPUT POWER vs. TOTAL HARMONIC DISTORTION (at 4 ohms, NORMAL IMP mode)

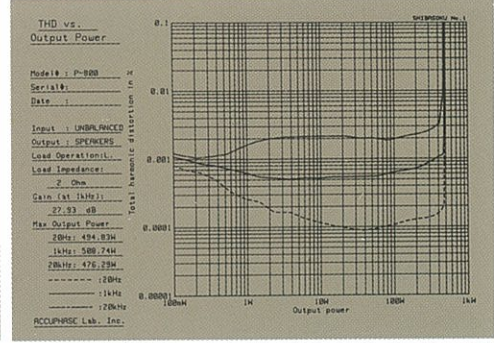

● OUTPUT POWER vs. TOTAL HARMONIC DISTORTION (at 2 ohms, LOW IMP mode)

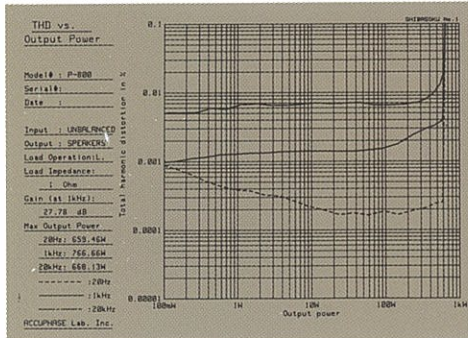

● OUTPUT POWER vs. TOTAL HARMONIC DISTORTION (at 1 ohms, LOW IMP mode)

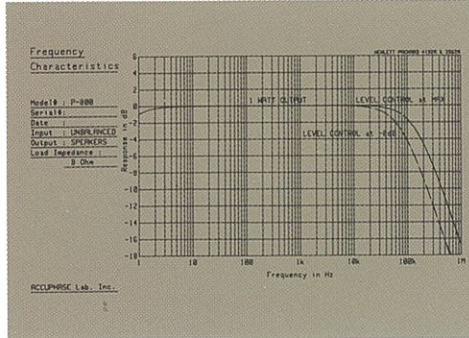

● FREQUENCY CHARACTERISTICS

GUARANTY SPECIFICATIONS (Guaranty specifications are measured according to EIA standards RS-490.)

● Performance Guaranty

All Accuphase product specifications are guaranteed as stated.

● Continuous Average Power Output (20 to 20,000 Hz)

NORMAL load impedance operation (THD: 0.01%)
600 W/ch into 4 ohms
400 W/ch into 8 ohms
200 W/ch into 16 ohms
LOW load impedance operation (THD: 0.05%)
600 W/ch into 1 ohm
400 W/ch into 2 ohms
200 W/ch into 4 ohms

● Total Harmonic Distortion

0.05% with 1- to 4-ohm load
0.01% with 4- to 16-ohm load

● Intermodulation Distortion

0.003%

● Frequency Response

20 to 200,000 Hz ± 0 dB
(for rated output, level control at maximum)
0.5 to 150,000 Hz +0, -3.0 dB
(for 1 watt output, level control at maximum)
0.5 to 80,000 Hz +0, -3.0 dB
(for 1 watt output, level control at -6 dB)

● Gain

28.0 dB

● Output Load Impedance

4 to 16 ohms in NORMAL load impedance operation
1 to 4 ohms in LOW load impedance operation

● Damping Factor (EIA, 50 Hz)

200

● Input Sensitivity

NORMAL load impedance operation
2.25 V for rated output into 8 ohms
0.12 V for 1 watt output into 8 ohms
LOW load impedance operation
1.13 V for rated output into 2 ohms
0.06 V for 1 watt output into 2 ohms

● Input Impedance

Unbalanced: 20 kilohms
Balanced: 40 kilohms

● Signal-to-Noise Ratio (A-weighted)

125 dB with input shorted, at rated output
95 dB with 1-kilohm input termination, at 1 W output

● Power Level Meter

Logarithmic compression scale, peak reading -60 dB to +3 dB and direct watt-reading scale

● Semiconductor Complement

158 transistors, 20 FETs, 15 ICs, 158 diodes

● Power Requirements

100 V, 117 V, 220 V, 240 V 50/60 Hz AC

● Power Consumption

110 watts + 110 watts idle
610W + 610W in accordance with IEC-65
740 watts + 740 watts at rated power output into 8 ohms

● Dimensions

481 mm (18-15/16 inches) width, 239 mm (9-13/32 inches) max. height, 489 mm (19-1/4 inches) depth

● Weight

47.2 kg (103.8 lb) net, 55.2 kg (121.4 lb) in shipping carton

Accuphase
ACCUPHASE LABORATORY INC.